

PUMP MODELS

▶ Agilent MS-301

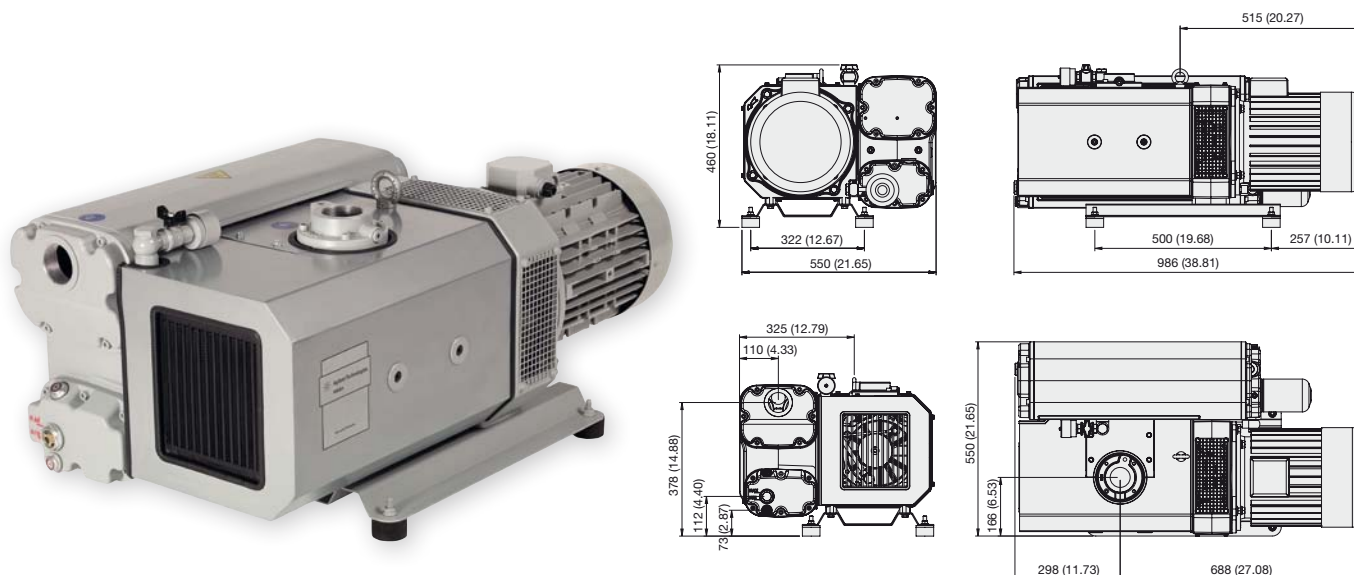

Dimensions: millimeters (inches)

Technical Specifications

Free air displacement	60 Hz: 350 m ³ /hr, 210 cfm 50 Hz: 290 m ³ /hr, 170 cfm
Pumping speed*	60 Hz: 290 m ³ /hr, 170 cfm 50 Hz: 250 m ³ /hr, 150 cfm
Ultimate partial pressure (with gas ballast closed)	≤ 8 × 10 ⁻² mbar (≤ 6 × 10 ⁻² Torr)
Ultimate total pressure (with gas ballast open)	≤ 0.5 mbar (≤ 0.37 Torr)
Power	60 Hz: 7.5 kW (10.0 HP) 50 Hz: 5.5 kW (7.4 HP)
Electrical motor characteristics	IM B5 Δ230/Y400 V at 50 Hz, Y460 V at 60 Hz IM B5 Δ400/Y690 V at 50 Hz, Δ460 V at 60 Hz IM B5 Δ220/Y380 V at 60 Hz IM B5 YY230/Y460 V at 60 Hz
Revolutions number	60 Hz: 1750 RPM 50 Hz: 1450 RPM
Water vapor tolerance	60 Hz/50 Hz: 40/30 mbar (30/23 Torr)
Water vapor capacity	60 Hz/50 Hz: 7/5 kg/h (7.7/5.5 qt/hr)
Noise level**	60 Hz/50 Hz: 76/72 dB(A)
Inlet port	Flange DN 63 ISO-K / 2" gas / 2" NPT
Exhaust port	2" gas / 2" NPT
Oil	type MS-01, charge 7 liter (7.4 qt)
Working ambient temperature range	+12 +40 °C (+54 +105 F)
Storage temperature	-20 +70 °C (+4 +158 F)
Dimensions	60 Hz: 1015 x 550 x 460 mm (40.3 x 21.6 x 18.1 in.) 50 Hz: 986 x 550 x 460 mm (38.8 x 21.6 x 18.1 in.)
Weight	
with 5.5 kW motor	188 kg (414 lbs)
with 7.5 kW motor	192 kg (423 lbs)
without motor	141 kg (310 lbs)

* According to PNEUROP 6602

** According to EN ISO 2151 (50/60 Hz)

HIGH CAPACITY MS-RPS SERIES

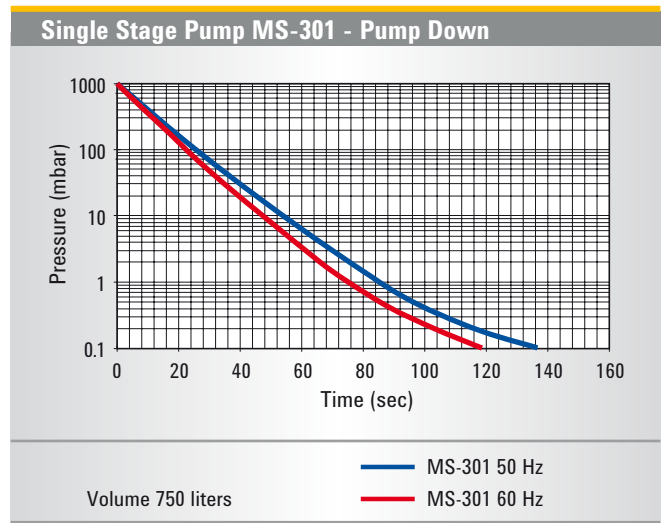
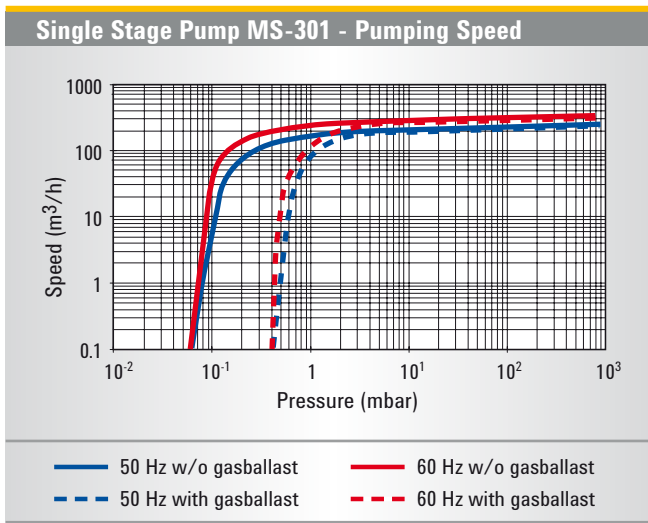

High Capacity MS-RPS Pumps

Ordering Information

High Capacity Rotary Vane Pumps *	Part Number
MS-301 5.5 kW, Δ230/Y400 V, 50 Hz; IE2; inlet 2" gas	X3752-64016
MS-301 5.5 kW, Δ230/Y400 V, 50 Hz; IE2; DN 63 ISO-K	X3752-64017
MS-301 5.5 kW, Δ400/Y690 V, 50 Hz; IE2; inlet 2" gas	X3752-64018
MS-301 5.5 kW, Δ400/Y690 V, 50 Hz; IE2; DN 63 ISO-K	X3752-64019
MS-301 7.5 kW, Δ230/Y400 V, 50 Hz - Y460 V 60 Hz; inlet 2" gas	X3752-64020
MS-301 7.5 kW, Δ230/Y400 V, 50 Hz - Y460 V 60 Hz; DN 63 ISO-K	X3752-64021
MS-301 7.5 kW, Δ230/Y380 V, 60 Hz; inlet 2" gas	X3752-64024
MS-301 7.5 kW, Δ230/Y380 V, 60 Hz; inlet DN 63 ISO-K	X3752-64025
MS-301 7.5 kW, YY230/Y460 V, 60Hz; inlet 2" NPT (US version)	X3752-64022
MS-301 7.5 kW, YY230/Y460 V, 60Hz; inlet DN 63 ISO-K (US version)	X3752-64023

* Oil charge not included

Oil and Accessories	Part Number
MS-01 Oil charge for MS-301 (7 liters)	X3760-64002
Inlet air filter with polyester cartridge, for 2" gas connection	9495059
Inlet air filter with polyester cartridge with DN 63 ISO-K flange	9495159
Connection fitting kit, for 2" gas connection	9495065
Connection fitting kit, for DN 63 ISO-K flange connection	9495165

Protective Accessories	Part Number
Pump thermal protection switch (to be ordered together with the pump)	9495076
Oil separator control pressure switch (to be ordered together with the pump)	9495077
MS-301 oil level protection switch (to be ordered together with the pump)	9495078

Spare Parts	Part Number
MS-301 minor spare part kit	9495020
MS-301 major spare part kit	9495021
Oil filter (type A)	9495070
MS-301 inlet air filter polyester cartridge	9495083
MS-301 exhaust coalescent filter kit	SR03706308